

CHAPTER 5

USE OF IMPROVED OPTICAL FIBRE REFRACTOMETER FOR THE MONITORING OF DEGRADATION OF LUBRICATING OIL

5.1 INTRODUCTION

Lubricating oils are employed in internal combustion engines and are required to perform a variety of task. Foremost is the minimization of wear. Due to its viscosity and non-compressible nature, lubricating oil keeps the moving components from contacting with each other. Lubricating oil is also used for resisting shear forces, minimize gear wear, maintain engine cleanliness and control acid corrosion, resist foaming and control rust corrosion. However, if the oil is highly viscous and has greater internal resistance then the oil tends to increase the temperature of the engine. Decrease in the viscosity of the oil also degrades the lubricating oil [69].

Viscosity plays an important role as it brings out the oil capacity to lubricate [70]. For this reason lubricant standard were developed. Nowadays oil viscosity is identified by its SAE (Society for Automotive Engineers) number. The thinner the oil, lower is its number, e.g. SAE 10 W. The numerical relates to viscosity at particular temperature and the letter 'W' indicates the oil suitability for colder temperatures. However, there is another service classification of oil apart from its viscosity, developed by API (American Petroleum Institute), which indicates service characteristics. It is graded on a scale from SA (the lowest) to SJ (the highest), for gasoline engines it is graded on a scale from CA to CG [71].

The viscosity of lubricating oil is affected by the temperature of the engine, the ambient temperature, its use in the engine, additives, shear forces etc. The temperature changes during use affects the viscosity. As the temperature increases, the viscosity decreases. Shear forces within the engine, especially during transmission, can also reduce the viscosity. Ambient temperature also reduces the oil viscosity. Oil thickens as the outside temperature decreases, leading to pumpability and circulation problems. Oil viscosity is also reduced due to normal use. Mechanical activity causes shear forces that cause the oil to lose its viscosity, reducing its load carrying capability. Engines operating at high RPM are subject to high shear rates. Thus the oil in such conditions loses its viscosity quickly [69].

Fluid temperature grossly affects chemical stability and particularly the oxidation rate of the basic elements of oil [71]. The primary accelerator of all oxidation reactions is temperature. Like any other reaction, the oxidation rate of hydrocarbons will approximately double for every 15 degree Celsius increase in temperature. Below 60 degree Celsius, the reaction is comparatively slow, but the life of oil is reduced by 50 per cent for every 15 degree Celsius temperature rise above 60 degree Celsius, according to the Arrhenius equation for chemical reaction rates. Hence, for high-temperature applications, the oxidation stability of oil can have great significance [72].

Lubricating oils are exposed to various contaminants depending on the operating conditions, the fuel quality, the ambient conditions and operating parameters and the rate of deterioration of lubricating oils strongly depends on all these factors. Degraded lubricating oil may contain contaminants like water, soot carbon particulates, acid combustion products, glycol, ferrous and non-ferrous metallic particles. The degradation of most oils imply the generation of molecules that are generally more polarized than the large hydrocarbon molecules which are weakly polarized. At the same time, unnecessary oil changes should be curtailed in order to reduce environmental impact and reduce the danger to land and aquatic species, by employing the lubricating oil more efficiently and minimize used lubricating oil waste [73].

Summarising the above discussion, the condition of lubricating oil should be monitored because of the following reasons-

- Degraded oil used in engines will increase the friction and thus the wear and tear among the moving components.
- Degraded oils contain chemical additives and soot particles that increase the friction and temperature of the engine.
- The degraded oil when removed from the engine and deposited in the soil can cause environmental hazard and endanger the health of humans, plant and animal species.

Thus it is necessary to monitor the degradation of lubricating oil so that the oil could be removed when degraded to a predetermined extent.

The degradation of lubricating oil is measured by several methods. Jim and Park, S., used the capacitive sensor method of detection of contamination in lubricating oil and estimated its quality by observing the change in the value of dielectric constant when different oil samples are placed as dielectric medium in the capacitive sensor [74]. This sensor was designed for the measurement of the change in capacitance according to the change of permittivity between the electrodes.

Agoston, A., *et al.* [75] proposed a novel sensor monitoring corrosion effects in lubricating oil. The sensor was fabricated using multiple sacrificial copper film layers with a resistive read-out and tested for measuring the corrosion which causes degradation in lubricating oils.

Harvey, T. J., *et al.* [76] studied about the effects of electrostatic charges on lubricating oil which can degrade the quality of the oil. It is an experimental investigation into the effect of lubricating oil quality on tribocharging.

Kuntner, J., *et al* [77] proposed a sensor to sense the deterioration of mineral oil (lubricating oil and insulating oil). In this work, the application of a miniaturized thermal conductivity sensor for the monitoring of water contamination and deterioration processes in mineral oil is shown. The sensor, which works on the hot-film principle, features a molybdenum resistive structure simultaneously serving as heater and sensing element. The experimental results show that both water contamination and deterioration processes in

mineral oil lead to an increased thermal conductivity indicating the potential of thermal conductivity sensors in the field of oil condition monitoring.

The viscosity of oil is needed to be monitored for the condition monitoring of lubricating oils. Agoston, A., *et al.* [78] presented a Viscosity sensor for engine oil condition monitoring. The system uses microacoustic sensors for the determination of viscosity of the oil samples.

Singh, S.K., *et al.* [79] carried out an experimental investigation to evaluate the effect of EGR on characteristics of lubricating oil with time of its usage. Exhaust gas recirculation (EGR) technique, which is being used widely to reduce and control the NO_x emissions from diesel engines. However, the use of EGR leads to rise in soot emission because of soot–NO_x trade-off. This EGR generated soot leads to several other problems inside the engine like degradation of lubricating oil, enhanced engine wear etc.

Assessment of the degradation of lubricating oil was performed on the lubricants which used in a four stroke engine. The lubricant properties examined in the assessment were lubricating capacity, viscosity and stability to oxidation. Lubricating capacity was evaluated by accelerated wear test on the Timken tester [80].

Guan, L., *et al.* [81] employed Dielectric spectroscopy to analyze the oxidation in degradation process of engine lubricating oil qualitatively and quantitatively and then comparing with Fourier Transform Infrared Spectroscopy (FTIR). It was found that both DS and FTIR can directly obtain the degradation features from the spectral data. Mignani, A. G., *et al.* [82] analyzed a collection of lubricant oils from different types of turbines, which were characterized by different degrees of degradation, by means of UV-VIS-NIR absorption spectroscopy, fluorescence spectroscopy and scattering measurements. All the measurements were performed by means of optical fibre-based instrumentation that made use of LEDs or compact lamps for illumination and miniaturized spectrometers for detection.

Imaz, B., *et al.* [83] used Magnetoelastic sensors based on the magnetoelastic resonance phenomena in the determination of viscosity. In this work an experimental prototype has

been used to determine the viscosity of lubricant oils using the magnetoelastic resonance. The measure of the viscosity is used to assess the degradation of oil.

The amount of degradation in lubricating oil can be estimated by measuring the amount of metal contaminants. Chaiyachit, C., *et al.* [84] used Hall effect sensor for measuring the contamination of lubricant in industry. This technique is based on the principle of the magnetic field and Hall Effect. The magnetic field is made up of a permanent magnet which is measured by a Hall Effect sensor. The measured magnetic field can be estimate the level of contaminants in the oil by the ferrous particles which indicate a lifetime of lubricant.

Raadnui [85] developed an on-line condition monitoring system oil-lubricated machinery to detects the relative variation of lubricant degradation by using the grid capacitance sensor in an on-line installation.

Idros, M. F. M., *et al.* [86] presented a synthesis process of condition based monitoring system of lubricant degradation in Application Specific Integrated Circuit (ASIC) for condition based monitoring system of lubricant degradation. For this work, an enhancement of a new algorithm for ASIC implementation is introduced. The Least Square Method (LSM) is used as an algorithm for lifetime prediction of lubricant where it written in Verilog language. Idros, M. F. M., *et al.* [87] employed UV/VIS Spectrometer to analyze the optical behavior of lubricant and the relation with real parameter of lubricant such as oxidation, Total Acid Number (TAN) and contamination. Idros, M. F. M., *et al.* [88] also presented an optical analysis of transmittance variation in lubricant oil due to the oxidation by using Embedded MATLAB Function (EMF) tools. A condition based technique is introduced to monitor the oxidation in lubricant engine oil by using EMF tool.

The lubricating oil is primarily a dielectric material with low dielectric losses [78]. With prolong use and effect of temperature, the dielectric (or non-conducting) properties of the oil decreases. By determining the dielectric constant, the amount of degradation of a lubricating oil sample can be determined. The amount of degradation in terms of dielectric constant is usually determined using capacitive sensor [74]

The dielectric constant of a material is related to the refractive index of the material and is mathematically given by the Clausius–Mossotti relation [89]. Clausius-Mossotti is used to determine the electrical polarizabilities of the atoms if the dielectric constant is known. Conversely by determining the dielectric constant, the electronic polarizability can be determined. The Clausius-Mossotti relation in terms of refractive index and microscopic polarizability of the molecules of the dielectric is given by the Lorenz–Lorentz formula [89]. The Lorenz–Lorentz relation “connects Maxwell’s phenomenological theory with the atomistic theory of matter” [90, p1541]. It is typically assumed that the number density of molecules is sufficiently small so that the Lorentz-Lorenz formula can be simplified to a simple linear relationship between the mean molecular polarizability and the dielectric permittivity (which is related to the refractive index of matter).

Thus the microscopic polarizability of lubricating oil can be related its refractive index by the Clausius-Mossotti relation and the Lorentz-Lorenz formula. Again the density, polarizability and dipole moment of lubricating oil is related to the dielectric constant by the Debye equation [91]. As the density and viscosity of lubricating oil is related to temperature, the effect of temperature on lubricant oil should also be studied along with its degradation.

Since $\epsilon_r = n_l^2$, (as shown by the Clausius–Mossotti equation) [89], where ϵ_r is the dielectric constant and n_l is the refractive index, the relation of RI with temperature, polarizability, dipole moment, density, molecular mass and kinematic viscosity can be used for finding the degradation of lubricating oil.

One of the common methods of measuring the RI of a material is the use of a Refractometer [7-22, 46-67]. The effect of temperature on the refractive index of a liquid has been studied by taking the simultaneous measurement of refractive index and temperature [56, 57]. When the refractive index of the medium surrounding the refractometer changes, then it results in varying intensity of light received at the receiver. The receiver converts the optical signal into electrical signals.

Microcontroller systems provide a convenient technique of sampling the analog signal from the optical detector and converting the analog signals into digital signals for processing and storage. Microcontroller system has been used in many previous works in

sampling and processing signals obtained from measurement systems using optical fibres [92-95].

When two or more inputs present in a measurement system needs to be correlated with the output, then Artificial Neural Network (ANN) is a way to model any input to output relations based on some input output data. The origins of ANNs can be traced back to a publication by McCulloch and Pitts, W., [96] of the first mathematical model of a biological neuron in 1945. The ANN was inspired by investigations into the structure of the human brain that consists of interconnected neurons [97]. An ANN is made up of interconnecting artificial neurons within input, hidden and output layers. It has two modes of operation: training mode and operation/testing mode. In the training mode, neurons are trained using a particular input pattern to produce the desired output pattern. In the operation/testing mode, when a taught input pattern is detected at the input, the ANN will produce its associated output.

ANN as a mathematical tool has been used in the assessment of the quality of lubricant oil. Liang, T.K., *et al.* [98] proposed a portable, compact and inexpensive fluorescence sensor for monitoring the ageing of retail lubricant oils as a result of the operation in an internal combustion engine. The proposed sensor consists of a UV laser diode, an optical fibre probe for simultaneous excitation and collection of the fluorescence and a USB powered palm-size spectrometer connected to a laptop. The variation of the spectra has been resolved using ANN [98].

This chapter describes an instrumentation system to assess the degradation of lubricating oil using an optical fibre sensor probe (OFSP), whose sensing element is a BTBMOF and a temperature sensor. To prepare the BTBMOF, the method described in chapter four and work done by Laskar and Bordoloi, S., [99] is adopted. At first, a multimode optical fibre having a length of thirty centimetres is taken. A portion of the fibre measuring 45 mm around the center of a multi-mode optical fibre is made open by removing the plastic jacket and then the method as described in chapter four and [99] is used. After following the procedure the length of the BTBMOF was made approximately 47 mm. The bare and tapered portion of the optical fibre sensor is given a shape of a semicircular arc of fixed radius of curvature to add macro bending effect along with the power coupling effect. The

BTBMOF is used to fabricate an OFSP, using a Diode laser source and a LDR as a detector. Laser beam from the Diode laser source is applied at one end of the OFSP. The power of the Laser beam is transmitted through the bare, tapered and bent portion of the multi-mode optical fibre depends on the RI of the liquid applied around it. The laser beam propagating through the BTBMOF is applied on the surface of the LDR. The resistance value of the LDR changes according to the change in refractive index value of the liquid surrounding the BTBMOF. The LDR is connected across a +5V supply with a series resistance to form a potential divider circuit. The output of the LDR based potential divider circuit changes according to the change in resistance of the LDR which is again a function of refractive index of the liquid in which the BTBMOF is immersed. LM35, a temperature sensor IC is used for giving output voltages according to change in temperature of the lubricating oil when it is heated up. A trained ANN is used to process and calibrate the input data. The parameters, such as weightage matrix elements and threshold of the trained ANN, are stored in the microcontroller flash memory to determine the degradation of lubricating oil sample using the voltage of the LDR based potential divider circuit and the output of LM35 temperature sensor.

5.2 PRINCIPLE OF BARE, TAPERED AND BENT MULTIMODE REFRACTOMETER

The BTBMOF is considered as the sensing element for the proposed microcontroller system to measure RI of a liquid. The bare and tapered portion of the optical fibre sensor is given a shape of a semicircular arc of fixed radius of curvature. The geometry of the proposed refractometer is the same as shown in Figure-4.1 in chapter four.

The geometry of the proposed sensor shows that the expression of power associated with laser beam at the output end of the fibre for the BTBMOF portion of the OFSP when exposed to air and in liquid medium (referring to equation 4.17 and 4.18)

$$P(L)_{air} = P_0 [1 - 0.2304(K_3 - K_4 n_{air}^2) \exp\{-K_5 (b - K_6 n_{air}^2 - K_7)^{3/2}\}] \quad (5.1)$$

$$P(L)_l = P_0 [K_1 - K_2 n_l^2] \left[1 - 0.2304 (K_3 - K_4 n_l^2) \exp \left\{ -K_5 (b - K_6 n_l^2 - K_7)^{3/2} \right\} \right] \quad (5.2)$$

where,

$$K_1 = \frac{n_1^2}{R^2(n_1^2 - n_{cl}^2)}, \quad K_2 = \frac{1}{R^2(n_1^2 - n_{cl}^2)}, \quad K_3 = \frac{2bn_1^2 k_0 L}{n_1}, \quad K_4 = \frac{2bk_0 L}{n_1}, \quad K_5 = \frac{2}{3} n_1 k_0 R', \quad K_6 = \frac{b}{n_1^2} \text{ and } K_7 = \frac{2a_0}{R'}$$

L is the length of the bent portion of the BTBMOF and $P(L)$ is the output power for the BTBMOF and P_0 is the power coupled into the input end of the fibre, n_l is the RI of the medium around the bare, tapered and bent region of the OFSP, R' is the fixed radius of curvature, R is the taper ratio $\left(= \frac{a_l}{a_0} \right)$.

5.3 RELATION BETWEEN REFRACTIVE INDEX, VISCOSITY AND TEMPERATURE

The relation between the dielectric constant ϵ_r and the microscopic polarizability α_p , of the molecules constituting the lubricating oil is given by the Clausius–Mossotti [89] relation as

$$\alpha_p = \frac{3}{N} \left(\frac{\epsilon_r - 1}{\epsilon_r + 2} \right) \quad (5.3)$$

where, ϵ_r is the permittivity (dielectric constant) of the oil, α_p is the polarizability and N is the number of molecules per unit volume.

Again from [89], it is shown that

$$\frac{n_l^2 - 1}{n_l^2 + 2} = \frac{1}{3} \sum_i n_{li} \alpha_{pi} \quad (5.4)$$

where n_l is the refractive index of the oil and $n_l^2 = \epsilon_r$.

$N\alpha_p = \sum_i n_{li} \alpha_{pi}$ represent that the individual polarizabilities are additive.

Equation (5.4) is called the Lorenz–Lorentz relation.

Equation (5.4) is further modified as-

$$\frac{M n_l^2 - 1}{\rho_l n_l^2 + 2} = \frac{1}{3} A \alpha_p$$

Therefore,

$$\frac{n_l^2 - 1}{n_l^2 + 2} = \frac{A \rho_l \alpha_p}{3M} \quad (5.5)$$

where A is the Avogadro's number (6.02×10^{23} molecules of oil/mole), ρ_l is the density of the oil (gram/cm³) and M is the molecular weight of the oil (gram/mole).

According to Stokes-Einstein relation [70],

$$\begin{aligned} \mu_0 &\propto \rho_l \\ &= \vartheta_0 \rho_l \end{aligned}$$

Therefore

$$\rho_l = \frac{\mu_0}{\vartheta_0} \quad (5.6)$$

where μ_0 is the dynamic viscosity and ϑ_0 is the Kinematic viscosity

Effects of temperature on solvent viscosity can be correlated by the following well-accepted empirical relation [100]

$$\mu_0 = A' \exp \frac{B}{T - T_0} \quad (5.7)$$

where A' and B are constants, T_0 is the reference temperature and T is the absolute temperature in degree Kelvin. Substituting equation (5.6) and (5.7) in (5.5), gives

$$\frac{n_l^2 - 1}{n_l^2 + 2} = \frac{AA' \alpha_p}{3M \vartheta_0} \exp \frac{B}{T - T_0} \quad (5.8)$$

Taking $\frac{AA' \alpha_p}{3M \vartheta_0} \exp \frac{B}{T - T_0} = K_8$, equation (5.8) becomes-

$$n_l^2 - 1 = K_8 \times (n_l^2 + 2)$$

Or

$$n_l^2 = (2K_8 + 1)(1 - K_8)^{-1}$$

Or

$$n_l^2 = 1 + 3K_8 + 3K_8^2 + 3K_8^3 + \dots \dots \dots + 3K_8^{n+1} \quad (5.9)$$

The higher order terms can be neglected if $K_8 \ll 1$. To determine a possible value of K_8 , the following values are taken for Solvent dewaxed high parafanic oil (which is a lubricating oil) [101].

- i. Viscosity $\vartheta_0 = \frac{8.4mm^2}{sec} = 8.4 \times 10^{-3}pa - sec$
- ii. Average molecular mass $M=280gm$
- iii. Polarizability value is taken only for carbon molecules
 $\alpha_p=11 \times 1.64878773 \times 10^{-41}$ Coulomb.metre²/Volt [102]
- iv. Avogadro's number $A (6.02 \times 10^{23}$ molecules of oil/mole)
- v. $A' = 0.000575Pa - S$ and $B = 980K$ [100]
- vi. $T_0 = 150.13K$ [100] and $T = 313K$ (for 40°C)

From these values K_8 has been calculated as 3.65126×10^{-18} .

Since $K_8 \ll 1$, the higher terms can be neglected. Thus equation (5.9) can be expressed as-

$$n_l^2 = 1 + 3K_8$$

$$\text{Or } n_l^2 = 1 + \frac{AA'\alpha_p}{M\vartheta_0} \exp \frac{B}{T-T_0} \quad (5.10)$$

$$\text{Or } n_l = \sqrt{1 + \frac{AA'\alpha_p}{M\vartheta_0} \exp \frac{B}{T-T_0}} \quad (5.11)$$

Equation (5.11) describes a relation among refractive index (n_l), Kinematic viscosity (ϑ_0), Molecular mass (M) and Temperature (T).

From equation (5.1) and (5.2), after following the experimental procedure as described in chapter 4 and [99], the function F is modified and given as-

$$\frac{V_{air}^2}{V_l^2} = F = \frac{[1 - 0.2304(K_3 - K_4 n_{air}^2) \exp\{-K_5(b - K_6 n_{air}^2 - K_7)^{3/2}\}]}{[K_1 - K_2 n_{liq}^2] [1 - 0.2304(K_3 - K_4 n_{liq}^2) \exp\{-K_5(b - K_6 n_{liq}^2 - K_7)^{3/2}\}]} \quad (5.13)$$

where F is a function describing the relation between the output power coming out of the fibre expressed in terms of electrical voltage when the OFSP is kept in air and test liquid. The refractive indices of air and test liquid are designated as n_{air} and n_l respectively. Since the refractive index of air is constant ($n_{air} = 1.0003$), therefore the numerator is a constant quantity. Thus F is a measurement variable of the refractive index of the liquid surrounding the BTMOF portion of the fibre.

Thus the function F is given as-

$$F = \frac{K_9}{[K_1 - K_2 n_l^2] [1 - 0.2304(K_3 - K_4 n_l^2) \exp\{-K_5(b - K_6 n_l^2 - K_7)^{3/2}\}]} \quad (5.14)$$

Using the expression of n_l , in equation (5.14), function F is modified as-

$$\frac{V_{air}^2}{V_l^2} = F = \frac{K_9}{\left[K_1 - K_2 \left\{ 1 + \frac{AA' \alpha_p}{M \vartheta_0} \exp \frac{B}{T - T_0} \right\} \right] \left[1 - 0.2304 \left\{ K_3 - K_4 \left(1 + \frac{AA' \alpha_p}{M \vartheta_0} \exp \frac{B}{T - T_0} \right) \right\} \exp \left\{ -K_5 \left(b - K_6 \left(1 + \frac{AA' \alpha_p}{M \vartheta_0} \exp \frac{B}{T - T_0} \right) - K_7 \right)^{3/2} \right\} \right]} \quad (5.15)$$

The term $\left[K_1 - K_2 \left\{ 1 + \frac{AA' \alpha_p}{M \vartheta_0} \exp \frac{B}{T - T_0} \right\} \right]$ of equation (5.15) represents the power coupled to the bare and tapered portion of BTBMOF along with the effect of viscosity, polarizability and temperature on the refractive index of liquid surrounding the BTBMOF.

The term $\left[1 - 0.2304 \left\{ K_3 - K_4 \left(1 + \frac{AA' \alpha_p}{M \vartheta_0} \exp \frac{B}{T - T_0} \right) \right\} \exp \left\{ -K_5 \left(b - K_6 \left(1 + \frac{AA' \alpha_p}{M \vartheta_0} \exp \frac{B}{T - T_0} \right) - K_7 \right)^{3/2} \right\} \right]$ represents the effect of bending, introduced at the tapered portion of the BTBMOF along with the effect of viscosity, polarizability and temperature on the refractive index of liquid when the tapered portion of the BTBMOF is bent.

Equation (5.15) shows that the function F is mainly dependent on the term $\frac{AA' \alpha}{M \vartheta_0} \exp \frac{B}{T - T_0}$.

Analysis of equation (5.14) and (5.15) shows that as the temperature of the test sample is increased, the values of the term n_l decreases then the term $K_2 n_l$ decreases, thus increasing $(K_1 - K_2 n_l)$. Again in the tapered and bent region of the fibre, due to decrease in n_l the term $\left[1 - 0.2304 (K_3 - K_4 n_l^2) \exp \left\{ -K_5 (b - K_6 n_l^2 - K_7)^{3/2} \right\} \right]$ increases. Thus the inverse of the product of the two terms in the denominator results in decrease of function F . Thus the value of the function F (equation 5.15) decreases with increase in temperature.

Thus
$$F \propto \frac{1}{T - T_0} \quad (5.16)$$

5.4 DESCRIPTION OF THE OPTICAL FIBRE SENSOR PROBE (OFSP)

The multimode optical fibre selected for the preparation of bare, tapered and bent refractometer, has a dimension of 200/230 diameter (core diameter (μm)/ cladding diameter (μm)). The RI of the core (n_1) and cladding (n_{cl}) of the fibre are 1.48 and 1.46 respectively. The length of the fibre is 30 cm. The bare, tapered and bent portion of the optical fibre sensor probe is prepared according to the procedure described in chapter 4 and [99]. The uncladded portion of the length is approximately 45 mm. The tapered ratio of the fibre is found to be 1.11. The taper ratio is determined as follows-

- An image of the tapered region is taken and put in image processing program in Matlab to convert the image into a grey scale or binary image.
- Using edge detection and filter function, the boundaries of the fibre was obtained following the works of Canny [103]. Distance between Pixels [104] function was used to find distance between pixels at the tapered and untapered region.
- Taking the ratio of pixel distance between the tapered and untapered region, the taper ratio is found out, which correspond to the actual taper ratio of the object (i.e. the fibre).

The optical fibre with bare and tapered portion is placed within a PVC tube having diameter 1.0 cm, by keeping the bare and tapered portion exposed outside (Figure 5.1). The PVC tube is filled with m-seal for keeping the fibre at the center. At one end of the PVC tube, the LDR is placed in such a way that the laser beam emerging out of the fibre is incident on the LDR surface perpendicularly. Similarly, the position of the Diode Laser Source is fixed in the other end of the plastic tube with proper focusing. The Diode Laser Source (Make Optochem International, 5mW power) and the LDR (surface diameter 3.8mm) are fixed firmly with the help of screws, so that their positions remain intact. The resistance of a LDR has inverse-linear characteristics with the light incident on the LDR surface (in unit of Lux) in the range of 0.1-10,000 Lux. The power supply point of the Diode Laser Source is connected to one terminal of the LDR and LM35 temperature sensor and they are connected to a stabilized 5V supply. The LDR is a part of the potential divider

circuit whose output is fed to the ADC pin 0 of ATmega 32 microcontroller. The output of the LM35 is fed to the ADC pin 0 of the microcontroller. As the LM35 gives the temperature in terms of analog voltage, to know the actual temperature, a type K thermocouple connected to a digital multimeter is used. The lubricating oil samples are heated by using an electric heater whose heating is controlled by adjusting an auto-transformer. The output of the LM35 is fed to the ADC pin 1 of ATmega 32 microcontroller.

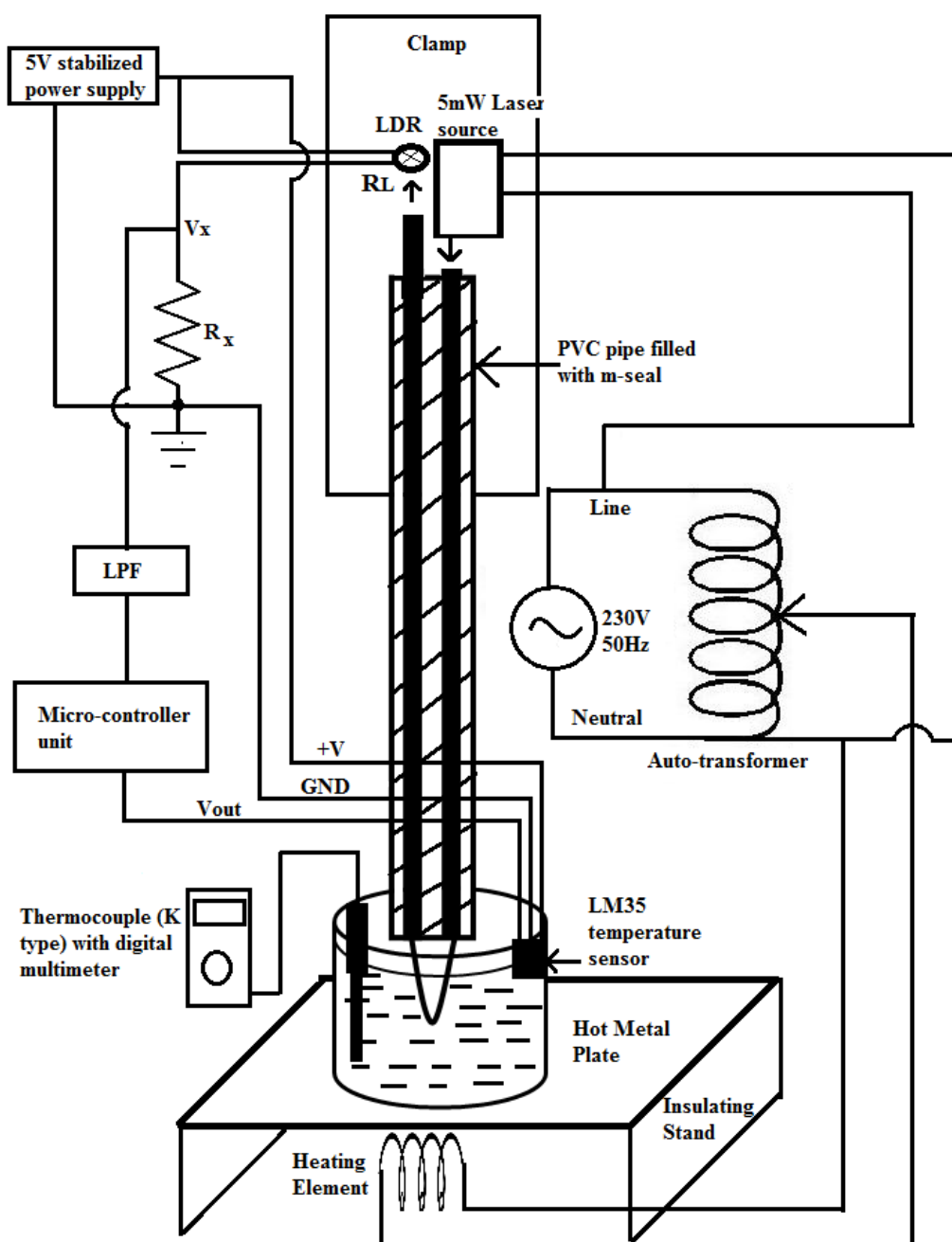

Fig.5.1: Experimental set-up containing BTBMOF probe, LM35, heating element and lubricating oil

5.5 SCHEME OF THE INSTRUMENTATION SYSTEM FOR THE OPTICAL FIBRE SENSOR

The LDR is connected across a 5 V DC supply with a series resistance with a fixed resistance R_x to form a potential divider circuit, as shown in Figure-5.2.

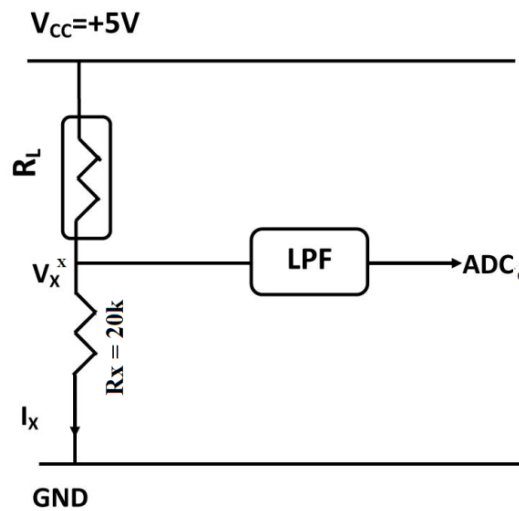

Fig. 5.2: LDR based potential divider circuit

where, $R_x = 20 \text{ k}\Omega$ and $V_{cc} = 5 \text{ V}$ and I_x is the current passing through the circuit. Thus, I_x decreases with increase in the value of R_L . Therefore, $V_x (=I_x R_x)$ also decreases with increase in R_L . The value of R_L increases with increase in refractive index of liquid applied around the sensing region of the OFSP.

The variation of power at the measurement point x can be expressed as [99]

$$P_x \propto \frac{1}{(R_x + R_L)^2} \propto V_x^2 \quad (5.17)$$

The LDR used in the potential divider circuit exhibits about 500Ω when it is exposed to laser beam directly to the diode laser source and shows $3 \text{ M}\Omega$ when the LDR is fully covered (i.e. no light is allowed to be incident on the LDR).

5.6. EXPERIMENTAL SETUP FOR THE INSTRUMENTATION SYSTEM

Figure-5.3 shows the configuration of the experimental setup used for the measurement of degradation of lubricating oil.

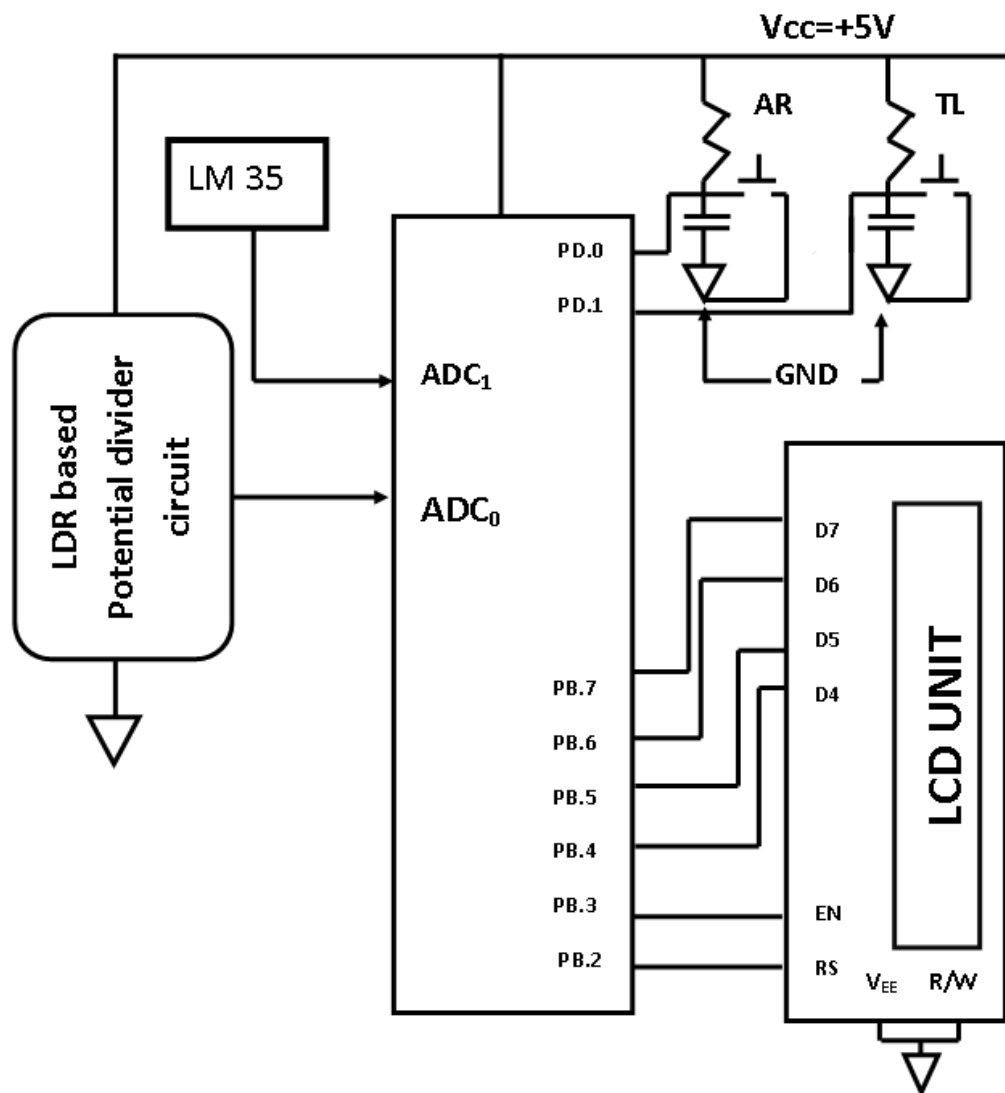

Fig. 5.3: Experimental setup for measuring the degradation of lubricating oil

It has a microcontroller ATmega 32 [44] which reads the analog voltage from the LDR based potential divider sensor circuit and temperature from LM35 temperature sensor [45] through its ADC0 channel (pin number 40, analog channel-0) via a LPF and ADC1 channel (pin number 39, analog channel-1). The display unit of the microcontroller system

consist of 16×2 (i.e. two rows having 16 character LCD display) LCD display units. The LCD has been configured as a 5×7 dot matrix 4 bit mode character display. It is interfaced to PORT-B of the microcontroller for display control. Switch AR (for air) and TL (for test liquid) are interfaced to pin PD.0 and PD.1 of Port D. These two switches are normally open type. Therefore, under normal condition, the status of PD.0 and PD.1 will be high. Whenever one of them is pressed, the status of PD.0 or PD.1 will be low depending upon the switch pressed. The status of these switches was utilized during the measurement steps.

5.7 MEASUREMENT PROCEDURE FOR THE OPTICAL SENSOR

Before starting the measurement, the BTBMOF portion of the optical sensor fibre is cleaned by immersing it in methanol(CH_3OH). The fibre is kept in air and the microcontroller samples the analog signal of the potential divider circuit which represents the value of V_{air} . The lubricating oil samples for the experiment are taken based on their use (in km) in four stroke bike engines. After this, the BTBMOF of the OFSP is immersed in the oil samples and heated from 30-100 degree Celsius and the microcontroller samples the analog voltage of the potential divider circuit (represented by V_x) and the output of LM35 temperature IC. The user then immerses the BTBMOF in a soap solution to properly clean the oil sticking onto the surface of BTBMOF of the OFSP. A calibration curve is obtained for the voltage readings of the potential divider circuit at different oil temperature (30-100) degree Celsius. A trained ANN is used to correlate the voltages of LDR based potential divider circuit and the output of the LM35 temperature sensor IC. The Weightage matrix for the trained ANN is obtained and implemented in the microcontroller unit to determine the degradation of the lubricating oil. The flowchart for the microcontroller program is shown in Figure 5.4.

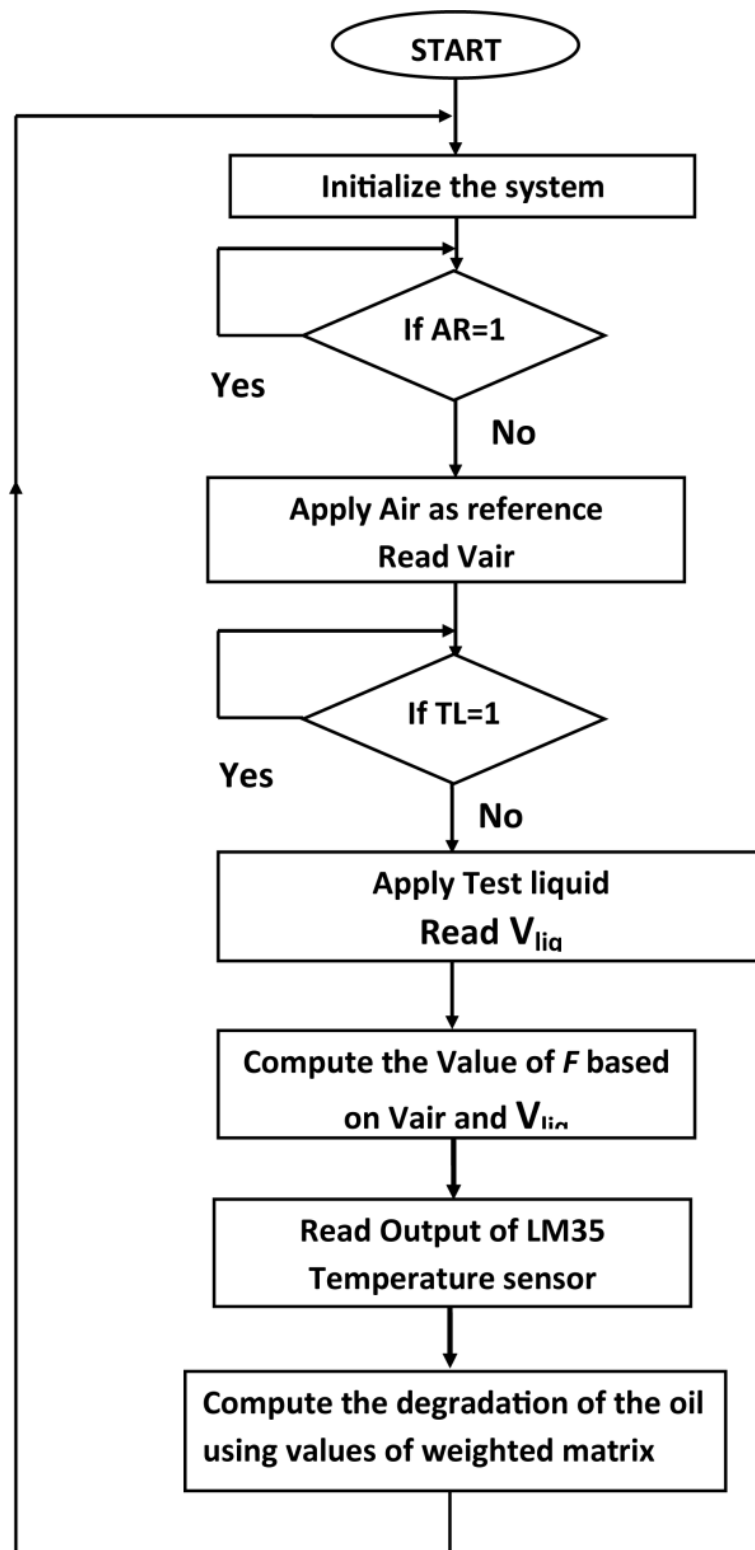

Fig. 5.4: Flow chart of the microcontroller program

5.8 RESULTS AND DISCUSSION

Lubricating oil gets degraded when it used in a motor vehicle. Thus more is the distance travelled by the motor vehicle; more is the degradation of the lube oil. High temperatures and contaminations degrade the quality of lubricating oil.

To generate data cycles to train an ANN for the purpose of correlating the voltages of LDR based potential divider circuit (which is a function of RI), and the output of LM35 temperature sensor IC measuring the temperature of lubricating oil samples to the degradation of the samples, used lubricating oil samples with known amount of usage (in terms of km) were collected from the same model of four-stroke engine bikes (Hero Glamour) using same grade 10W-30 SJ synthetic engine oil (Hero 4T Plus). All lube oil samples were taken in a 100mL glass beaker and heated from 30-100 degree Celsius. The microcontroller samples the voltage of the LDR based potential divider circuit via the LPF and output of LM35 temperature sensor IC.

The experimental results for different samples of lubricating oil at different temperature are presented in Table-5.1 and the plot of Function F vs. temperature (30°C to 100°C) is shown in Figure- 5.5.

| | | Decimal values | | | | | |
|---------------------|----------------|---------------------|-----------------------|-----------------------|------------------------|------------------------|------------------------|
| | | 849 | 818 | 851 | 846 | 876 | 891 |
| Temp. of oil sample | Decimal values | Oil 1 0km | Oil 2 540km | Oil 3 800km | Oil 4 2600km | Oil 5 3050km | Oil 6 5858km |
| 30 | 061 | 45 | 43 | 41 | 28 | 28 | 27 |
| 35 | 071 | 46 | 44 | 42 | 27 | 24 | 23 |
| 40 | 081 | 49 | 45 | 43 | 29 | 23 | 22 |
| 45 | 092 | 55 | 46 | 46 | 31 | 23 | 22 |
| 50 | 102 | 58 | 52 | 50 | 33 | 24 | 22 |
| 55 | 112 | 62 | 56 | 52 | 35 | 25 | 23 |
| 60 | 122 | 65 | 57 | 54 | 36 | 26 | 24 |
| 65 | 132 | 67 | 59 | 56 | 37 | 27 | 25 |
| 70 | 143 | 70 | 61 | 57 | 42 | 28 | 26 |
| 75 | 153 | 72 | 63 | 59 | 44 | 29 | 27 |
| 80 | 163 | 73 | 65 | 61 | 45 | 31 | 29 |
| 85 | 173 | 76 | 71 | 64 | 47 | 33 | 31 |
| 90 | 184 | 78 | 73 | 68 | 49 | 34 | 32 |
| 95 | 194 | 79 | 75 | 70 | 50 | 36 | 35 |
| 100 | 204 | 82 | 77 | 74 | 55 | 40 | 37 |

Table 5.1: The experimental results for the BTBMOF with different oil samples and corresponding values of voltage of potential divider circuit and output of temperature sensor

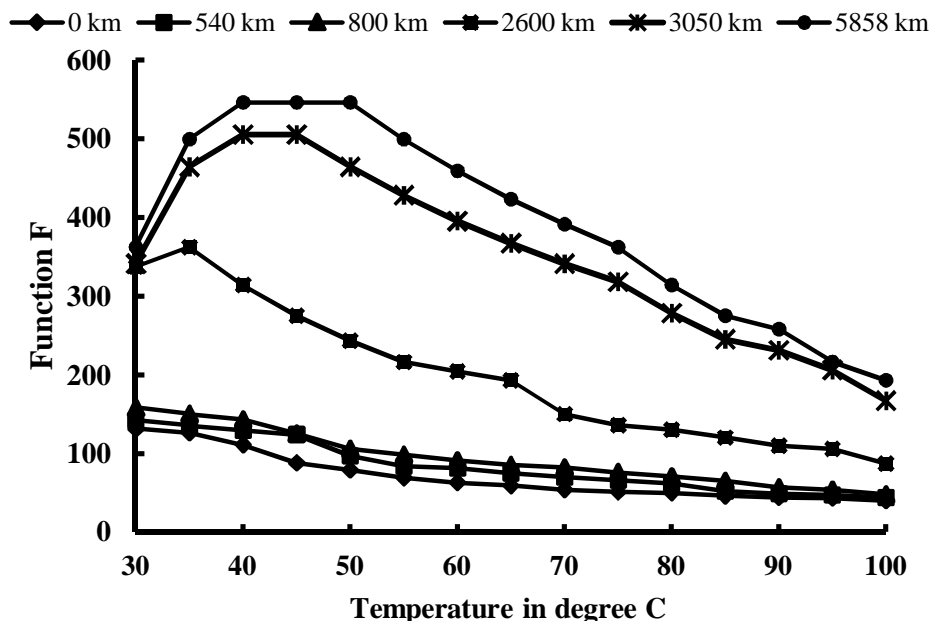

Fig. 5.4: Variation in Function F with temperature

Test results plotted in Figure 5.5 shows a general trend of decrease in the value of function F with increase in temperature of the test sample as predicted by equation 5.13, 5.14 and 5.15. Only two most used oil samples (oil 5 and oil 6) shows an initial rise within temperature range (30-45) degree Celsius. It is observed in some of the curves that after 50 degree Celsius, the curves show a downward slope in the function F but the slope falls more sharply above 50 degree Celsius. These is in contrast to the statement that below 60 degree Celsius, the reaction is comparatively slow, but the life of oil is reduced by 50 per cent for every 15 degree Celsius temperature rise above 60 degree Celsius, according to the Arrhenius equation for chemical reaction rates [72]. Since the oil samples were already degraded, the downward slope in the function F starts at 50 degree Celsius.

The ANN used for the purpose of correlating the usage, RI and temperature of lubricating oil samples, contain two neurons in at the input layer, four neurons at the hidden layer and one neurons at the output layer as shown in Figure-5.6. Each layer has different functions. The input layer is used to receive the inputs and acts as a distribution centre by fanning out the inputs to the first hidden layer. Within the hidden layer section, each hidden layer will first activate and transform the data before propagating them to the next layer. Output layer

neurons are normally taken to be the same as for neurons in the hidden layer, but as a result, they limit the dynamic range of the output to between +1 and -1 [105].

The measure of the output of temperature sensor, voltage of the LDR based potential divider circuit and usage of shown in Table-1. The output of temperature sensor and voltage of the LDR based potential divider circuit (which is a measure of refractive index) are taken as the input to the ANN input layer. The output layer of the ANN with one neuron provides the degradation of the lubricating oil samples.

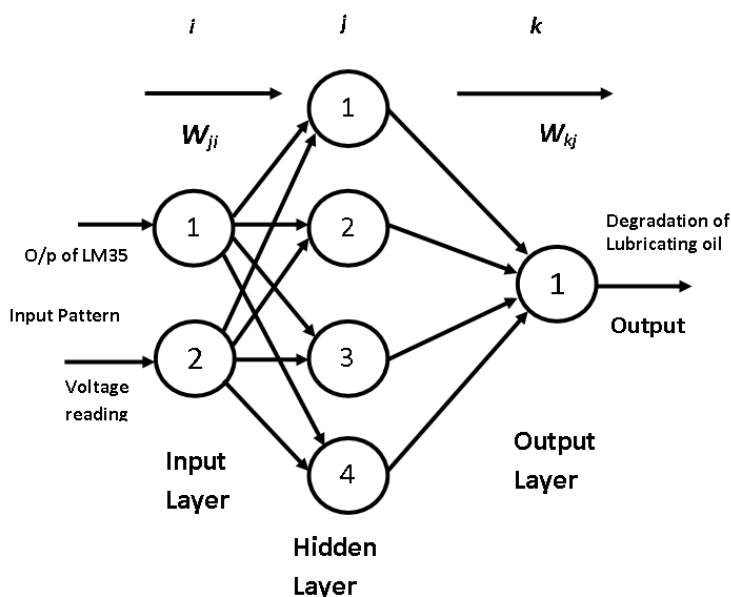

Fig. 5.6: Configuration MLFF ANN used to correlate RI and temperature of a lubricating oil sample to its degradation.

The experimental results presented in the Table-1 provides 90 training cycles for temperature range 30 – 100 degree Celsius, for oil samples with usage from 0.0 to 5858 km and the corresponding values of the output of the potential divider circuit (in terms of decimal values). The output is basically an index for judging the quality of oil. This index is based on a linear scale (oil usage 0.0 km = 0.1 and 6000 km = 0.99). Back propagation technique is used to train the ANN using these 90 data cycles. The training of the ANN is terminated, when difference between calculated output from the ANN and desired output becomes less than 0.001.

The ANN algorithm with these trained weightage matrix elements is implemented in the microcontroller based system to determine the relative degradation of lubricating oil by measuring the output of temperature sensor and voltage of the LDR based potential divider circuit.

Weightage matrix elements between input and hidden layers and, hidden layers and output layer for the trained ANN are as follows:

Between first neuron and the neuron of hidden layer

$$W_{11} = 9.871442 \quad W_{12} = -6.115482$$

$$W_{13} = 0.200000 \quad W_{14} = 0.200000$$

Between second neuron and the neuron of hidden layer

$$W_{21} = 9.871442 \quad W_{22} = -6.115482$$

$$W_{23} = 0.200000 \quad W_{24} = 0.200000$$

Between hidden layer neurons and output layer neurons

$$W_{31} = -22.104653 \quad W_{32} = -22.104653$$

$$W_{41} = -23.811239 \quad W_{42} = -23.811239$$

The ANN algorithm with these trained weightage matrix elements is implemented in the microcontroller-based system to determine the degradation of lubricating oil by measuring the output of temperature sensor and voltage of the LDR based potential divider circuit.

5.9 CONCLUSION

A bare, tapered and bent multimode optical fibre (BTBMOF) sensor and LM35 temperature sensor with ATmega32 based microcontroller system have been developed to find the degradation of lubricating oil.

The degradation of lubricating oil mainly affects the viscosity of oil. The presence of dirt, carbon particles, metals etc increases the viscosity of the oil and decreases the lubricating property of the oil. The degradation of lubricating oil is further enhanced if the lubricating oils are heated to a very high temperature.

The Clausius–Mossotti equation is used to relate the refractive index of the lubricating oil to its viscosity, polarizability, dipole moments, molecular weights etc. The refractive index of the lubricating oil was determined using the BTBMOF sensor. Since the degradation of oil is dependent on temperature, the lubricating oil is heated from 30° to 100°C and a LM35 temperature IC sensor is used to measure the increase in temperature of the oil. The expression of refractive index (from Clausius–Mossotti equation) is related to the measurement equation of the BTBMOF sensor and an output equation relating the change in output voltage (which is a function of refractive index) to the different parameters which contribute to the degradation of lubricating oil.

The reading of the voltage across the potential divider circuit is plotted against the temperature and a curve with downward slopes at higher temperature is obtained. It can be observed that the downward slope of the curve is more prominent when the oil temperature is greater than 50 degree Celsius.

Data cycles have been generated to train an ANN for the purpose of correlating the measure of RI, usage and temperature of lubricating oil samples, standard lubricating oil samples with known usage are taken. These lubricating oil samples are then subjected to temperature variation from 30-100 degree Celsius. The measured values of output of temperature sensor and voltage of the LDR based potential divider circuit are fed to the neurons of the input layer. The processing is done in the hidden layer which consists of six neurons. The output which is a measure of the degradation of the lubricating oil is obtained at the output neuron of the output layer.

Software has been developed to implement the algorithm of the trained ANN in the microcontroller based system to determine the degradation of lubricating oil sample at any temperature between temperature 30-100 degree Celsius by sampling the voltage of the LDR based potential divider circuit and output of temperature sensor through ADC0 and ADC1 respectively. The use of ANN ensures better correlation among the input-output variables as degradation of lubricating oil is varying non-linearly with respect to the measurement variables i.e. LDR based potential divider circuit and output of temperature sensor.